

UV TECHNOLOGY

Technical Documentation
ELC[®] N3HV / ELC[®] N4HV / ELC[®] N5HV



eta plus electronic gmbh

Lauterstraße 29, 72622 Nürtingen, Telefon +49 7022 6002-80, Fax +49 7022 65854, E-mail: info@eta-uv.de, www.eta-uv.de
Eingetragen unter HRB 724321 AG Stuttgart, USt.-Id.-Nr. DE 146267800, Geschäftsleitung: Uwe Uhlemann, Dr. Markus Roth

ELC[®] („Electronic Lamp Control“) is a registered trademark of
IST Metz GmbH.

Contents

1	Safety	1
1.1	Definition of Symbols	1
1.2	Safety Advice	1
1.3	Correct operation.....	2
1.4	Extended use	2
2	Description of functions	3
3	Installation	4
3.1	Mounting of casing	4
3.1.1	Back mounting	5
3.1.2	Side by side rack mounting.....	6
3.2	Connection	8
3.3	Control current connections.....	12
3.4	Explanations of the control functions for ELC.....	14
3.4.1	Release relay	14
3.4.2	Control input START.....	14
3.4.3	Setting lamp power	14
3.4.4	Table: lamp power	15
3.4.5	Earth Fault Detection	16
4	Operation of ELC	17
4.1	Initial operation	17
4.2	Switching on the ELC	17
4.3	Switching on the lamp.....	17
4.4	Dimming Operation	18
4.5	Standby Operation.....	18
4.6	Switching off the Lamp	18
5	Troubleshooting	19
5.1	Repair ELC	19
6	Technical Data	20

1 Safety

1.1 Definition of Symbols



Stop (Stop Danger). This symbol warns of serious danger of severe injury to persons. It must be strictly observed.



Attention (Warning). This symbol indicates information the non-observance of which can lead to extensive damage to property. The safety warning must be strictly observed.



Information. This symbol indicates key information on use. Non-observance can lead to failure.

1.2 Safety Advice



The ELC must be installed and connected in compliance with existing regulations and practices. This is e.g. EN 60204-1 in Europe.



Repairs on the ELC may only be carried out by the manufacturer



The installation and starting up may only be carried out by skilled electricians.



Do not open the ELC before it is disconnected from the mains. BEWARE OF RESIDUAL VOLTAGE! The unit may still be live up to three minutes after it has been switched off.



The ELC causes a leakage current greater than 3.5 mA!
Safeguarding by means of leakage current protection type A and type AC according to IEC 60755 is not permitted!
The ELC operates in principle as a frequency converter and is equipped with a mains filter whose leakage current could activate fuse protection.



Contact to the grounding connector must always be ensured.
Additional measures must be taken to ensure that there is no danger when touching the appliance. This could be by means of a universal leakage current protection type B, taking into consideration the increased response threshold, or by means of an independent equipotential connection

1.3 Correct operation



The ELC is an electrical unit intended to be installed in the switch cabinets of industrial high-voltage power installations. It is conceived as an electronic ballast for the operation of lamps intended for this purpose.

Any other use is deemed as misuse. The manufacturer will not assume liability for damage resulting from misuse.
A pre-requisite for authorised operation of the ELC is the observance of both the operating and maintenance instructions and the safety advice.

1.4 Extended use



Extended use beyond the operating specifications as stated is not permitted.
The manufacturer will not assume liability if the equipment is used in any other way. The operator acts at his own risk.



Any operation beyond the scope of the authorised operation is considered to be misuse.

2 Description of functions

The electronic ballast ELC is designed to operate medium pressure discharge lamps as described in chapter 6.

In contrast to conventional ballasts (inductive lamp ballast or transformer or transformer with transductor), the lamp with an electronic ballast is operated with high frequency (approx. 100 kHz). The lamp does not flicker and dimming is infinitely adjustable to a range between 20 % and 100 % of the electric power or to between 15 % and 100 % of the UV radiation respectively.

Dimming

The possibility of dimming the lamp has two advantages. Firstly the lamp can be switched to minimum load (standby operation) during longer idle times and energy can thus be saved. Secondly the optimum lamp power can be determined and adjusted as appropriate.

Power control

The ELC offers a high level of lamp power constancy due to its integrated power control. Variations in operating voltage of $\pm 10\%$ do not affect lamp power.

Ignition device

When the lamp is switched on the ELC initiates trigger pulses to fire the lamp; a separate ignition device is not required.

Other performance characteristics

- High level of electrical efficiency.
- The ELC has a network power factor of > 0.9 . It can be operated directly at the network without compensation.
- The potential-free control inputs allow various lamp conditions such as maximum lamp power, dimming or standby to be set.
- The digital control inputs are designed for control voltages of between 10 and 30 V AC or DC. Therefore ELC can be easily integrated into the installation's electric system.
- Lamp current and lamp power are continuously recorded and output as analogous 0-10 V signals.
- The ELC monitors the lamp cables for earth fault.
- The potential of both lamp outputs is separated from that of the supply voltage.
- The ELC is both short-circuit proof and safe in open circuit operation at the lamp output.

3 Installation

3.1 Mounting of casing



The ELC must be installed in a control cabinet with at least IP 54 protection (see EN 60529). Operation without a control cabinet or in a control cabinet with a lower degree of protection is not permitted.

The ELC may only be installed **vertically** (control connections at the bottom, power connection at the top) allowing for at least the minimum spacing as shown. No other positioning is possible.

Fig. 1 and Fig. 2 show the installation possibilities.

The ELC should not be mounted in the immediate proximity of sensitive electronic equipment. An appropriate distance must be maintained to scatter field transformers or other inductors.



The flow of cool air in ELC must be safeguarded. The ambient temperature must not exceed the values described in chapter 6!

The switching cabinet has to be air conditioned in consideration of total electrical losses and maximum ambient temperature.

If the air conditioning is realised by fans the minimum required air flow is described in chapter 6. The better the cooling situation the higher the expected lifetime.

Impure cooling air could affect the functionality of the ELC. This can be avoided by installing a fine air filter.

3.1.1 Back mounting

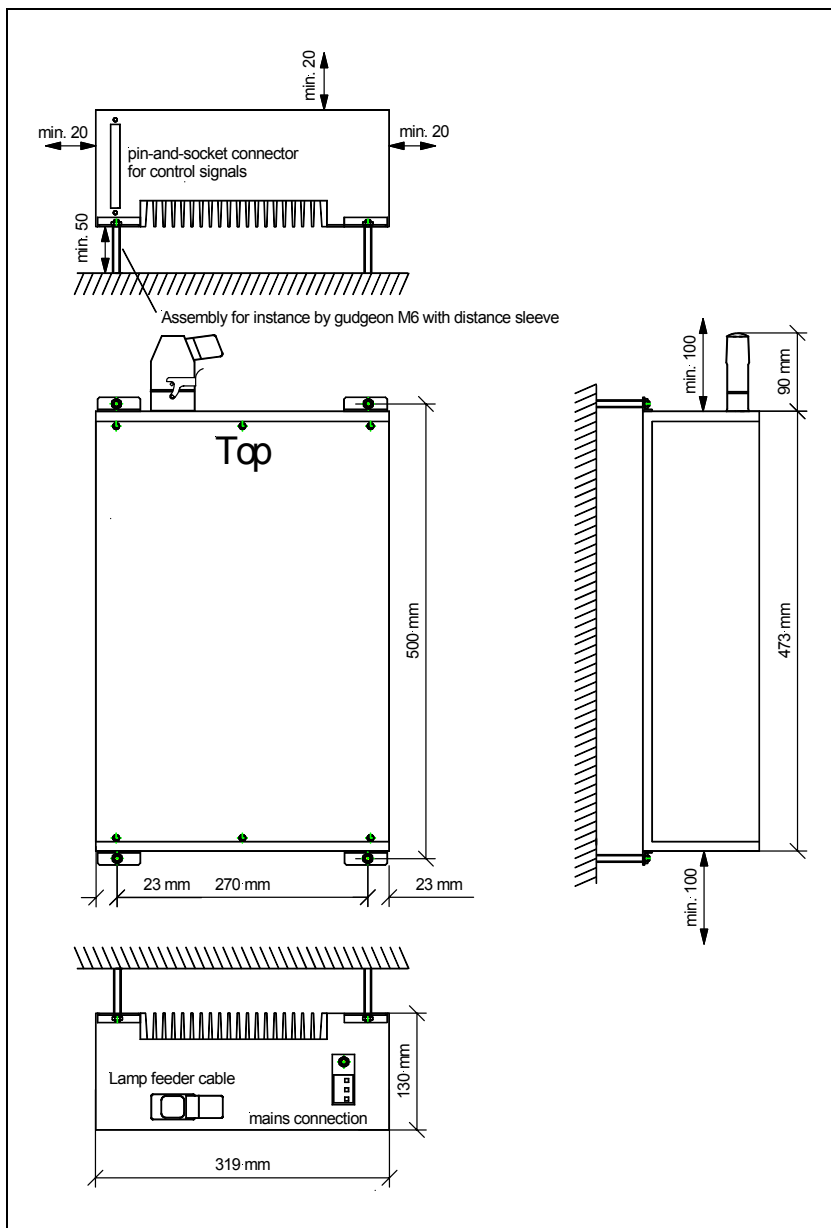

Fig. 1: Assembly of the ELC (all dimensions in mm).

3.1.2 Side by side rack mounting

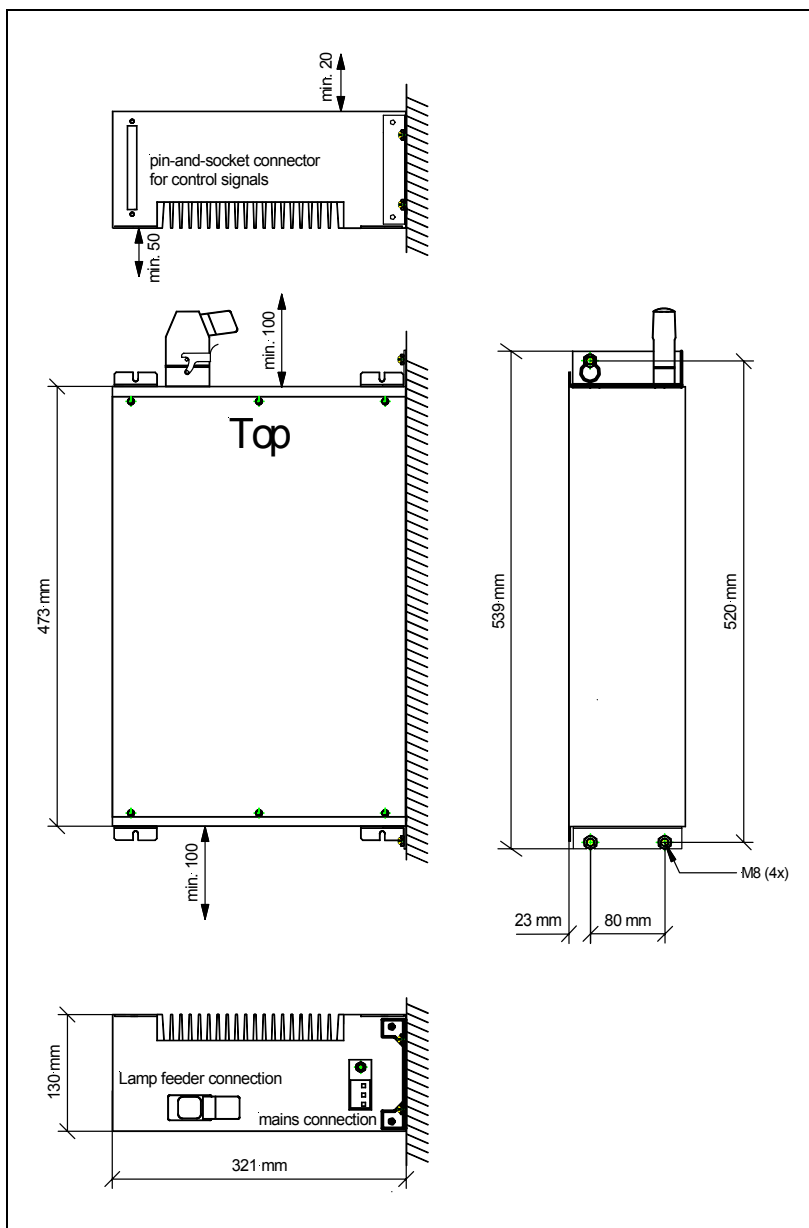
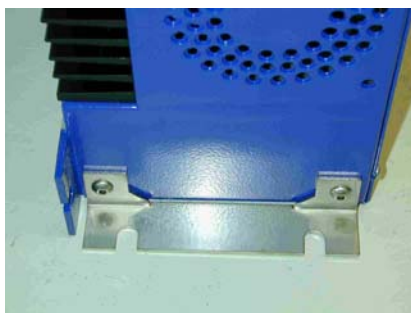

Fig. 2 side by side rack mounting with brackets

If “side-by-side rack mounting“ is preferred, assembly brackets and screws can be provided upon request..



Attach bracket to the upper surface of the appliance



Attach bracket to the underside of the appliance

3.2 Connection

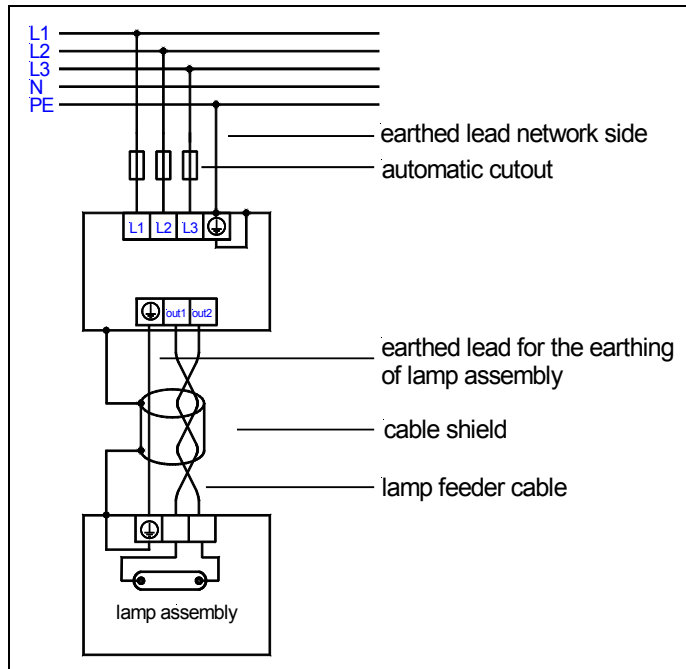

The power connections of the ELC are situated on top of the casing.

Fig. 3 shows the electrical wiring plan.

The lamp feeder cable shielding must be connected to the ELC. To this end the connector has an EMC screw connection (also see: connection lamp cable).

If wished, the shielding can also be connected to the lamp unit.

Fig. 3 Power connection



The connection of mains supply cables and lamp feeder cables must be separated from control cables.



Quality standards according to EN 50160 regarding mains frequency, voltage drops, transients etc. are required.

The one-phase short-circuit power at the supply point must be 20 times higher than the nominal power of the UV-installation (accordingly the short circuit current has to be 35 times higher than nominal current, alternatively the relative short-circuit voltage has to be 2.8% lower).

Mains connection



The mains connection of the ELC is situated at the top right.

The cross section of the earthed wire must be at least 4 mm².

The three phases must be provided with an automatic cut-out.

Fig. 4: Mains supply



In order to avoid damaging the terminal pins, please do not exceed the following torque:

- L1, L2, L3: **0,6 – 0,8 Nm**
- Grounding conductor: **3,0 – 4,0 Nm**

Connecting the lamp feeder cable



The lamp feeder cable must correspond with the cable parameters described in chapter Technical Data.



Connector assembly (from left to right)

- Carrier casing
- Casing gasket
- Hood and screws
- EMC cable gland with plastic insert

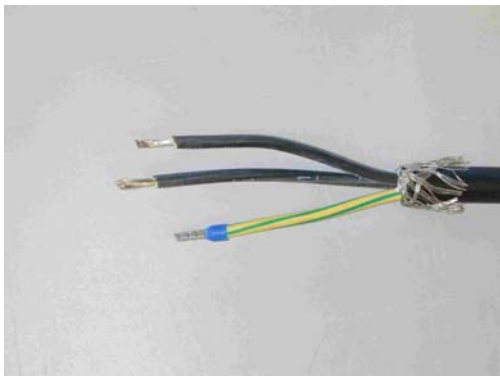

- Preparing the lamp feeder cable:
- Remove sheath
- Free metal braid and put over cable sheath
- Insulate conductor
- Ferrule the grounding conductor (if applied)

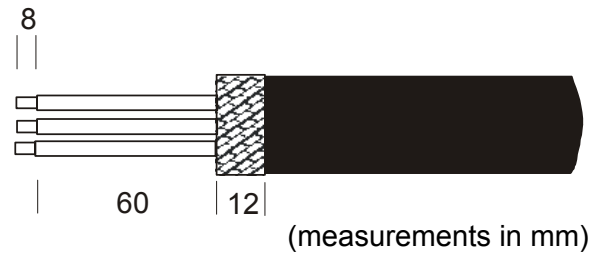

- Insert cable into the cable gland and bush casing

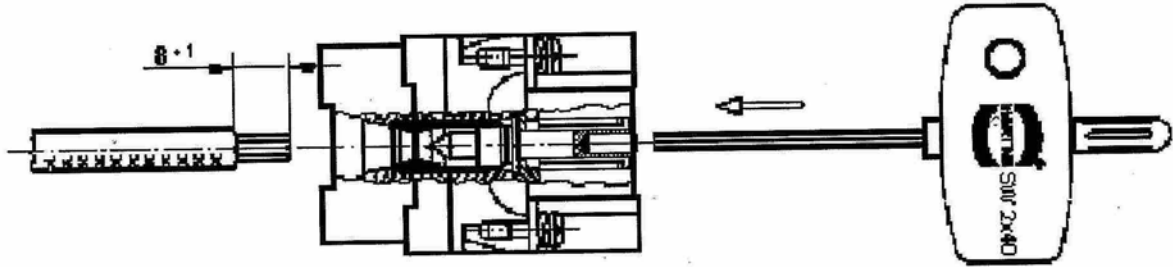

- Do not twist wires additionally
- Insert wires into the contact chamber so that the insulation is aligned with the tightening nut.
- When tightening the nut hold the wire in position.



Torque: 1Nm (permissible moment für screw driver =1.2 Nm)

Hexagon socket (jaw span 2)

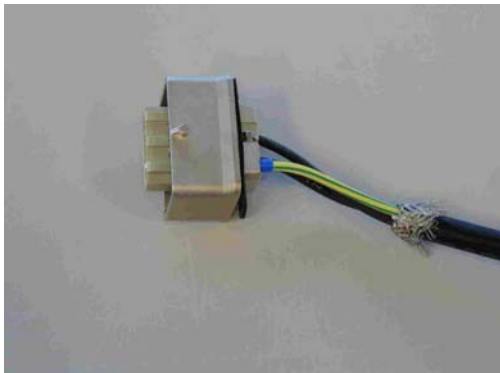

- Connect grounding conductor (if applied)



- Screw on hood. Recommended orientation: Cable gland in the direction of PIN1 (see picture below)
- Ensure that the shield evenly covers the plastic inset of the cable gland (360° contact)



- Tighten EMC cable gland

The lamp feeder cable between the switch cabinet and lamp assembly must be laid in a metal insulating tube. For the correct installation of the lamp assembly and lamp please observe the corresponding manufacturer's instructions.

3.3 Control current connections

The control wires are connected to the underside of the casing by means of the connectors.

On the underside there are two plug strips (see Fig. 5).

The pin connector is to be connected to the plug strip marked **Control**.

The pin assignment is shown in Fig. 6 and Chart 1.

All control circuits must be earthed upon installation.



Fig. 5: Control connections

Pin connection

1	2	3	4	5	6	7	8	9	10
Start1	Max1	Min1	+ 10 V DC	0-10V	P-lamp	I-lamp	ES1	n.c.	OK1
START	MAX	MIN	SET VALUE		PL	IL	ES		RELEASE
Start2	Max2	Min2	GND	GND	GND	GND	ES2	n.c.	OK2
20	19	18	17	16	15	14	13	12	11

Fig. 6: Pin plug for control of ELC

Designation	Pin No.	Description	
Start1	1	digital control input	15 - 30 V AC / DC, between Pin 1 and Pin 20 input impedance = 1 k Ω potential-free, active high
Start2	20	START	
Max1	2	digital control input	15 - 30 V AC / DC, between Pin 2 and Pin 19 input impedance = 1 k Ω potential-free, active high
Max2	19	MAX	
Min1	3	digital control input	15 - 30 V AC / DC, between Pin 3 and Pin 18 input impedance = 1 k Ω potential-free, active high
Min2	18	MIN	
+ 10 V DC	4	control voltage	for set value potentiometer 5 k Ω or 10 k Ω max. 10 mA
0-10V	5	analogous control input	set voltage between 0 –10 V and GND, input impedance > 200 k Ω control GND**
GND	16, 17	SET VALUE *	
P-Lamp	6	analogous output	0-10 V DC / 1 mA, (1 V \cong 1 kW), Reference: GND control GND**
GND	15	PL (lamp output)	
I-Lamp	7	analogous output	0-10 V DC / 1 mA, (1 V \cong 2 A), Reference: GND control GND**
GND	14	IL (lamp current)	
ES1	8	Relay earth contact ES contact, potential-free	up to 30 V AC / DC, max. 0,5 A Contact between Pin 8 and 13, closed in operation, opens in the case of fault
ES2	13		
OK1	10	RELEASE relay contact, potential-free	up to 30 V AC / DC, max. 0,5 A Contact between Pin 10 and 11, closed in operation, opens in the case of fault
OK2	11		

Chart 1: Control current connection of ELC

* PWM coupling upon request

** control GND: all pins designated control GND are internally connected and potential-free.

3.4 Explanations of the control functions for ELC

3.4.1 Release relay

The release relay indicates the trouble-free operation of the unit.

This means that the relay closes when the ELC (see 4.2) is switched on and remains closed during operation providing there is no defect.

A typical defect would be that the lamp does not fire.

3.4.2 Control input START

High: lamp is on

Low: lamp is off

By applying the High signal the lamp is fired and warms up at maximum current until the desired power is achieved (see below).

We recommend warm-up at maximum power. After a short time (approx. 2 mins) the full output has been reached and the lamp power can be varied as desired.

3.4.3 Setting lamp power

Stepless (infinitely variable)

The lamp can be dimmed steplessly from between approx. 20 % to 100 % of the nominal power. The lamp power is set by applying an analog voltage of between 0 V and 10 V to control input SET VALUE.

- 0 V corresponds to min. power P_{\min} (20 % of nominal value)
- 10 V corresponds to max. power P_{\max} (100 % of nominal value)

SET VALUE can be controlled manually by means of an external potentiometre.

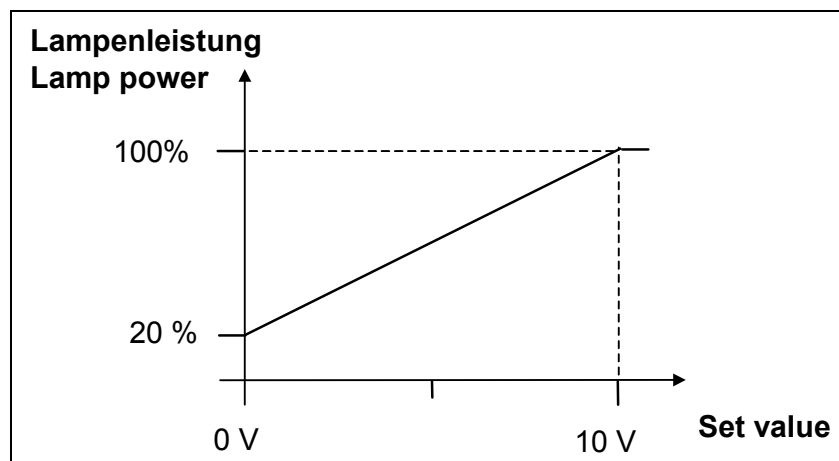

Fig. 7: Control characteristic

Digital: MIN und MAX

For certain operation modes the lamp power can be set to Maximum or Minimum independent of the control voltage at SET VALUE. E.g.:

- Lamp warm-up: maximum power or
- Standby operation: minimum power

To this purpose the control inputs MAX and MIN respectively are set to High, whereby the function MAX has the higher priority.

3.4.4 Table: lamp power

SET VALUE	MIN	MAX	Lamp power
0 – 10 V	LOW	LOW	stepless Minimum – Maximum
0 – 10 V	HIGH	LOW	Minimum
0 – 10 V	LOW	HIGH	Maximum
0 – 10 V	HIGH	HIGH	Maximum

3.4.5 Earth Fault Detection

The ELC (electronic ballast) has been fitted with an earth fault control system for test purposes (prototype).

The ELC is fitted with an earth fault relay **ES** for the purpose of indicating an earth fault. During trouble-free operation the relay is closed (provided the ELC is connected to the power supply voltage).

The earth fault control is also active when the lamp is switched off.



The lamp should not be switched on is the relay ES is open.

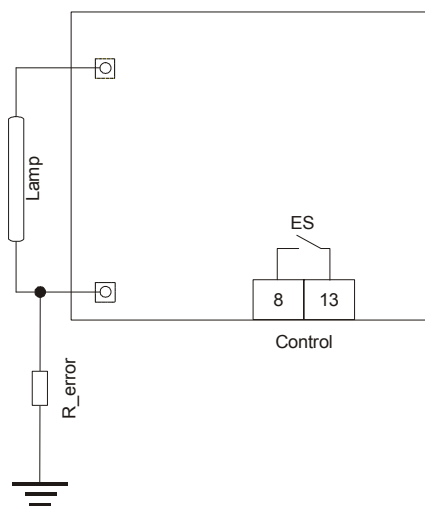

In the case of an earth fault through the insulating resistor R_{error} (see Fig. 8) the relay **ES** opens .

The error is only displayed, the ELC does not switch off the lamp. The error is also not stored by the ELC.

In order for the earth fault control to function properly it is essential that it be connected as prescribed, particularly the earth connectors.

The relay contact ES (pins 8 and 13 on the control connector) opens when the insulation resistance R_{error} is drops below approx. 200 kOhm.

Fig. 8: Earth Fault Control



If an earth fault occurs during lamp operation we recommend shutting down the installation rapidly and correcting the error. The lamp must not be started if earth fault has occurred.



In order to avoid an unwanted reaction of the earth fault control during faultless operation, the isolation resistance of the lamp cables and all lamp connectors must be greater than 10 Mohm.



If the release relay RELEASE (s. 3.4.1) is open the earth fault relay ES will not give clear information! In this case an error message "earth fault" should not be issued.

4 Operation of ELC

4.1 Initial operation

The operative parameters of the ELC, such as the scope of the trigger pulse when switching on the lamp, is set by the manufacturer.



Alterations to the manufacturer's settings can only be carried out by the manufacturer. Adjustment to the internal potentiometer can cause malfunction and damage to the equipment and is therefore prohibited.

You always have to ensure that the correct lamp type is used (see chapter 6) and that all wiring is properly connected !

4.2 Switching on the ELC

- The ELC is switched on by applying the operating voltage.

4.3 Switching on the lamp

- A HIGH signal is applied to the digital START control input to switch on the lamp.



If a HIGH signal has already been given to the digital START control input before the ELC is switched on, then the lamp will not start up. In the case of a power failure, the ELC cannot automatically switch on the lamp when power returns. Before switching on the lamp, a LOW signal must be applied to the digital control input.

Turn the ELC on maximum lamp power during the lamp warm-up period.

Maximum lamp power can be adjusted as follows:

- HIGH signal at the digital MAX control input or
- 10 V control voltage at the analogous SET VALUE control input.

During warm-up the lamp power stays at a very low level over a longer period of time and after approximately 60 seconds rapidly increases to its nominal power. The lamp is operated with increased power until the nominal power is reached.

4.4 Dimming Operation

After having reached nominal operation, the desired lamp power can be infinitely adjusted.

- Lamp power is adjusted via control voltage (0 – 10 V) at the analogous SET VALUE control input.

In this context, 0 V are tantamount to minimum and 10 V to maximum lamp power.



The adjustment of lamp power via the analogous SET VALUE control input is only possible if a LOW signal is applied to the digital MIN and MAX control inputs.

4.5 Standby Operation

During longer idle times the ELC can be switched to standby operation. The lamp is operated at minimum power but can be brought up to nominal power within a few seconds.

Standby operation is set as follows:

- a HIGH signal at the digital MIN control input or
- 0 V control voltage at the analogous SET VALUE control input.

The warm-up time from standby operation to nominal operation depends on the lamp's ambient conditions. If cooling is too intensive during standby operation, the acceleration time is prolonged.



The adjustment of standby operation is only possible if a LOW signal is applied to the digital control input MAX.

4.6 Switching off the Lamp

- The lamp is switched off by applying a LOW signal to the digital START control input.



In order to avoid heat accumulation in the ELC, the operating voltage should be left on for a few minutes. Before restarting, the lamp must be sufficiently cooled down as it cannot be fired otherwise.

5 Troubleshooting

Troubles	Possible causes	Corrective action
No RELEASE after having switched on the ELC. Relay RELEASE open	The ELC is not provided with operating voltage	Check fuses and voltage of terminals
	Lamp is switched-ON (control input START at HIGH)	Switch-OFF lamp
	Fault in ELC	Contact manufacturer, see 5.1
Lamp does not fire after being switched on, and the relay RELEASE opens	Lamp is too hot	Let lamp cool down, increased cooling probably required
	Lamp not connected	Check plug contacts between ELC and lamp
	Lamp defective	Replace lamp

5.1 Repair ELC

Only the manufacturer is permitted to repair the ELC. In case of failure please contact the following address:

eta plus electronic gmbh
 Lauterstraße 29
 D-72622 Nürtingen
 Tel: +49 7022 / 6002-80
 Fax: +49 7022 / 65854
 e-mail: Info@eta-uv.de

6 Technical Data

General data ELC

Mains frequency	50 / 60 Hz
Tolerance mains voltage	nominal voltage \pm 10 %
Recommendet air flow	90 m ³ / h per ballast
Control range	approx. 20 - 100 %
Firing voltage	1100 V / < 1 sek.
Protection	IP 20
Ambient temperature	0°C to +40°C in operation -20°C to +70°C during storage and transportation, before initial operation leave at least 4 hrs at room temperature
Permissible pollution	pollution severity 2 according to VDE 0110
Permissible humidity	relative atmospheric humidity 80 %, non-condensing
Dimensions (H x W x D)	approximately 500 x 320 x 130 mm
Weight	approximately 13 kg
Installation position	only vertical (lamp and power connection at the top; control connections at the bottom) respecting the minimum spacing in 3.1
EMC	Verified according to EN 55011 EN 61000-3-3 EN 61000-6-2
Safety	Verified according to EN 50178
Leakage current	Leakage current > 3 mA, see Chapter 1 "Safety"

Type specific data

Type	ELC N3HV-400-30	ELC N4HV-400-40	ELC N4HV- 480-40	ELC N5HV-400-40	ELC N5HV-480-40
Power factor	typ. 0,93	typ. 0,94	typ. 0,93	typ. 0,94	typ. 0,94
Power efficiency	typ. 0,96	typ. 0,96	typ. 0,96	typ. 0,96	typ. 0,96
Power supply	3 x 400 V	3 x 400 V	3 x 480 V	3 x 400 V	3 x 480 V
Supply current	4,9 A	6,7 A	5,6 A	8,3 A	6,8 A
Max. supply current	5,5 A	7,4 A	6,2 A	9,1 A	7,5 A
Line protection*	10 A	10 A	10 A	10 A	10 A
Lamp power	3 kW	4 kW	4 kW	5 kW	5 kW
Lamp voltage	300 V	400 V	400 V	400 V	400 V
Tolerance lamp voltage	± 7 %	± 5 %	± 5 %	± 5 %	± 5 %

*Line protection: 3-channel automatic cut-out characteristic C

Lamp feeder cable: approved types and lengths

The use of cable types which have not been approved by the manufacturer can lead to malfunction. The possibility of damage to the electronic ballast cannot be excluded.

Article no.	Type	ELC N3HV-400-30	ELC N4HV-400-40	ELC N4HV- 480-40	ELC N5HV-400-40	ELC N5HV-480-40
8036	Lamp feeder cable 1 kV 3 x 2,5 mm ² NR + PE Ø 10,5 mm	5-15 m	5-15 m	5-15 m	5-15 m	5-15 m
40017	"Y" form 1 kV / 10 m Lamp feeder cable, shielded Ø 10,5 mm	10 m				
8068	Lamp feeder cable 1,6 kV 2x2,5 mm ² Ø 10,5 mm	5-15 m	5-15 m	5-15 m	5-15 m	5-15 m

The data refers to distance between ELC and lamp.